

Guidelines
and Space Standards for
Barrier Free Built Environment
for
Disabled and Elderly Persons

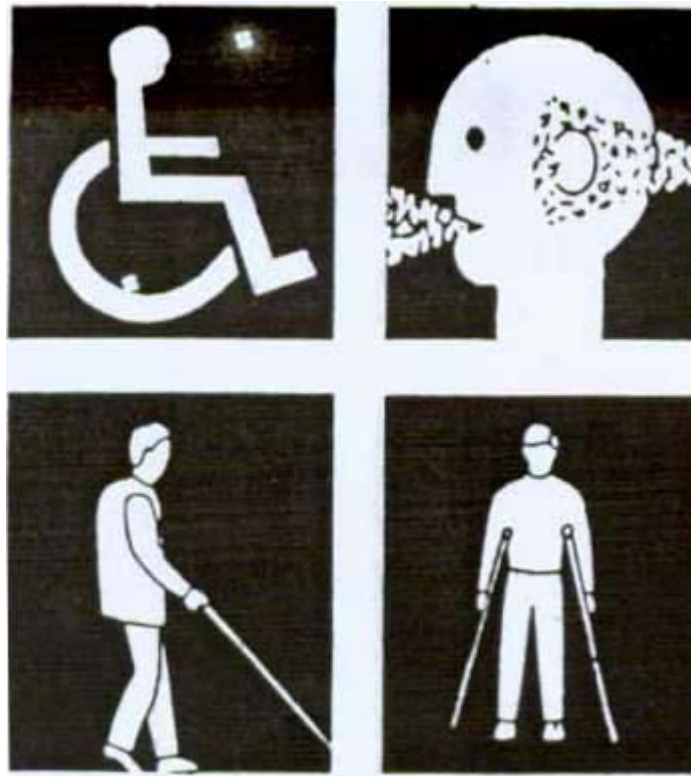

CPWD

Central Public Works Department
Ministry of Urban Affairs & Employment
India
1998

Controls

Controls

- For locking and opening controls for window and doors should not be more than 1400 mm from the finished floor usable by one hand.
- Switches for electric light and power as well as door handles and other fixtures and fittings should be between 900 mm - 1200 mm from finished floor.
- Power point for general purpose should be fixed between 400-500 mm from the finished floor.
(as shown in the Figures-1,2)

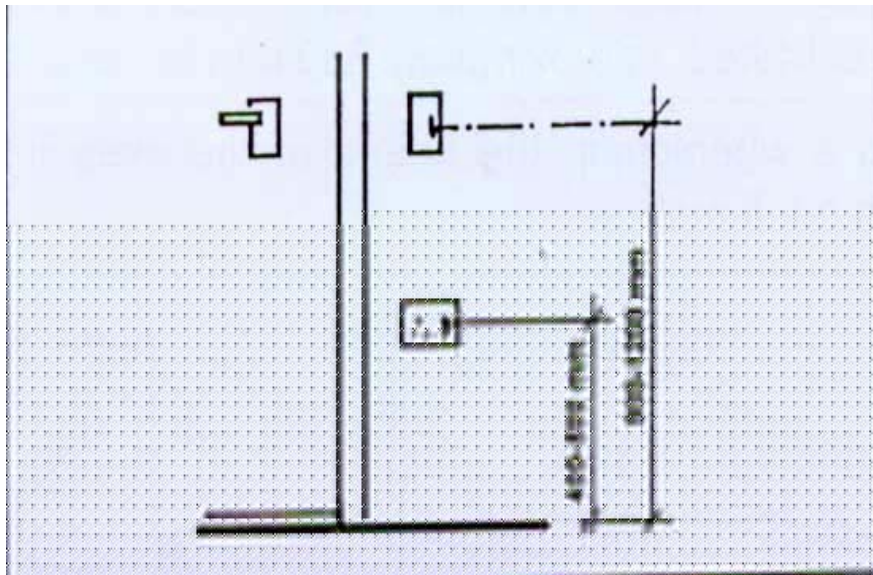

Fig-1. Heights for Switches, Doors, Handrails

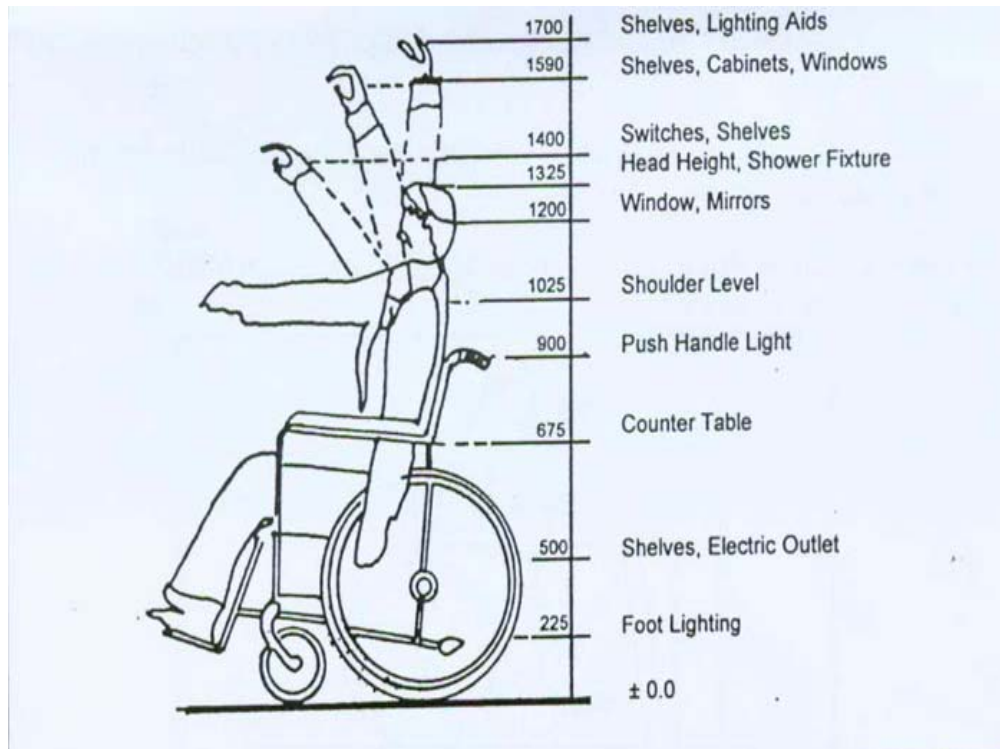

Fig-2. Typical Dimensions for Essential Uses with in easy reach

Range of Reach

- A wheelchair user's movement pivots around his or her shoulders. Therefore, the range of reach is limited, approximately 630 mm for an adult male.
- While sitting in a wheel chair, the height of the eyes from the floor is about 1190 mm for an adult male. (as shown in Figure-3)

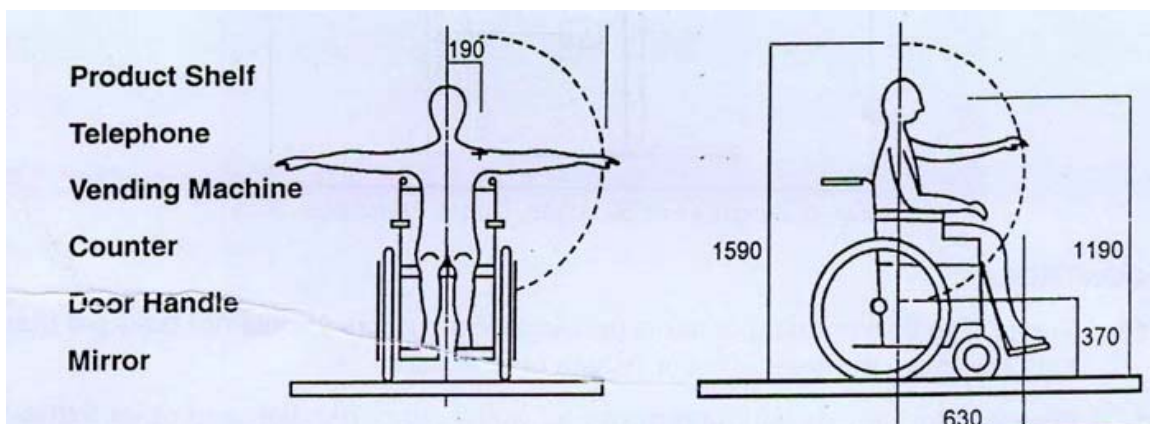

Fig-3. Range of Reach

- A wheelchair has a footplate and leg rest attached in front of the seat. (The footplate extends about 350 mm in the front of the knee). The footplate may prevent a wheelchair from getting close enough to an object.
 - a. Manually operated equipment must be designed to be easily accessible from a wheelchair.
 - b. Make sure that the coin slots of vending machines etc. are located no higher than 1200 mm.
 - c. Allow a space at least 350 mm deep and 700 mm high under a counter, stand, etc (as shown in Figure-4).

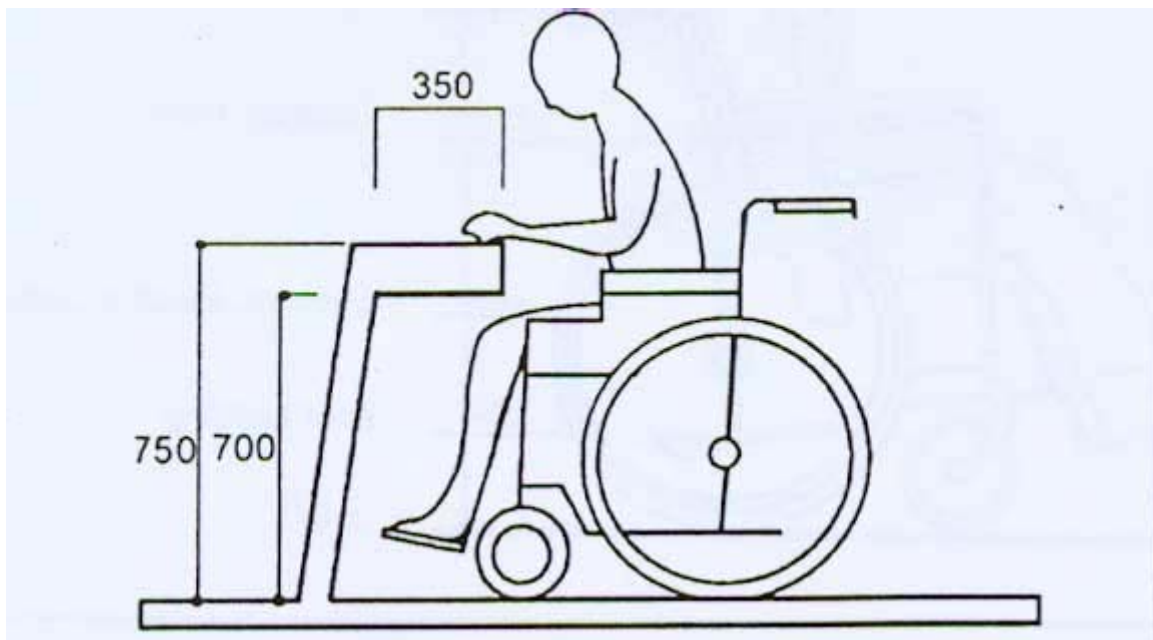

Fig-4. Space required for wheelchair footplate

Access Provisions

Minimum Access Provisions Required in Various Types of Buildings

| <u>Type of Building</u> | <u>Minimum Provisions</u> |
|--|---|
| <ul style="list-style-type: none">• Single detached, single dwelling units | A minimum of 2 per cent of the total number of units to be constructed with Barrier-free features. (Adoptable Units) |
| <ul style="list-style-type: none">• Staff housing, multiple dwelling and high rise residential units and Tenements | A minimum of 1 unit for every 25, plus 1 additional unit for every 100 units thereafter. Entrances and exits to be Accessible. |
| <ul style="list-style-type: none">• Tenement houses, row houses, Apartments and town houses | A minimum of 1 unit for up to 150 units and a minimum of 1 additional unit for every 100 units thereafter to be accessible. |
| <ul style="list-style-type: none">• Post offices, banks and financial Service institutions | A minimum of 1 lowered service counter on the premises. A minimum of 1 lowered automatic teller machine (ATM) / cash disbursement point on the premises. Stamp vending machine. |
| <ul style="list-style-type: none">• Shophouses and single-storey | Accessible shopping area. |
| <ul style="list-style-type: none">• Places of worship | Entrances and exits and main area of Worship to be accessible. Mosques: access to area for ablutions; Churches: access to confessionals, fonts and chapels; Temples: access to shrines and courtyards. |
| <ul style="list-style-type: none">• Food centres | A minimum of 1 table without stools or seats attached to the floor for every 10 Tables. |

A minimum of 2 tables without stools or seats attached to the floor for the whole premises.

Accessible entrance

- Community centres, village halls, Auditoria, concert halls, assembly halls, cinemas, theatres and other places of public assembly

Accessible entrances, exists, aisles and main community or public gathering areas.

Accessible toilet facilities should be nearby.

Seating for persons with disabilities to be accessible from main entrances and lobbies.

Various seating/viewing choice to be provided for persons in wheelchairs throughout the main seating area

A minimum of 2 wheelchair spaces for seating capacity up to 100 seats.

A minimum of 4 wheelchair spaces for seating capacity from over 100 to 400 seats.

Ramp Details

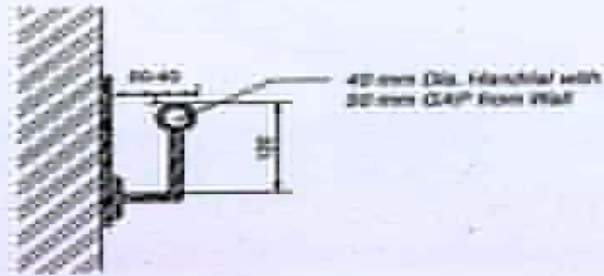

Fixing Detail of Handrail to the Wall

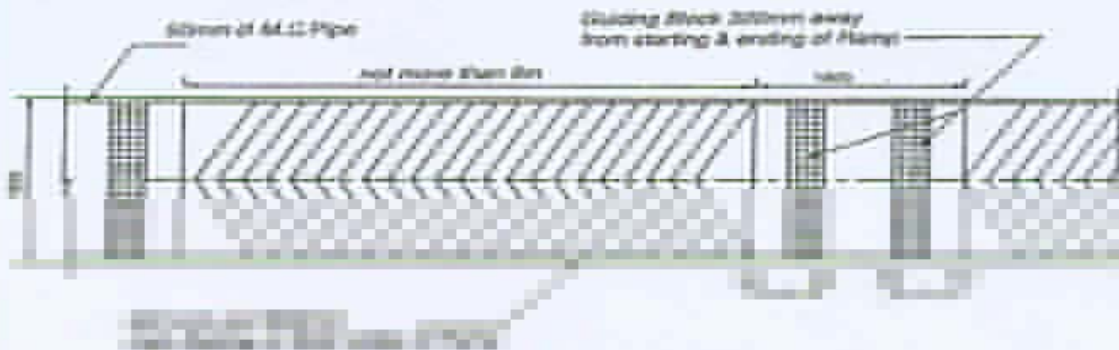
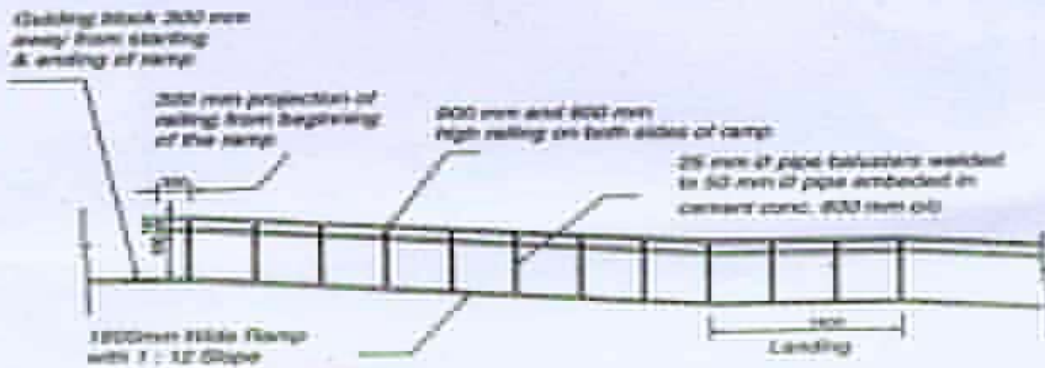
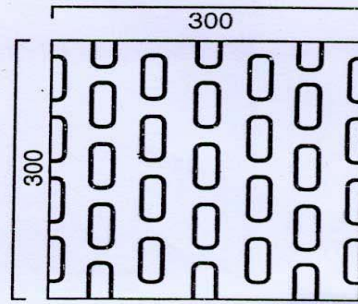
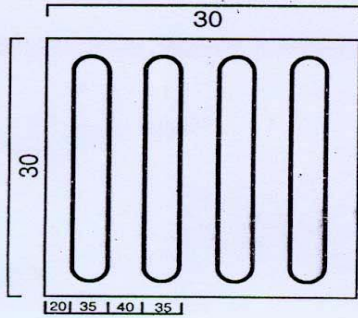

Fig-1. Details of Ramp for Wheelchair users and Disabled persons.

Guiding/Warning Floor Material

Shapes of guiding blocks for persons with impaired vision

(1) Shape of liner block



(2) Shape of spot block

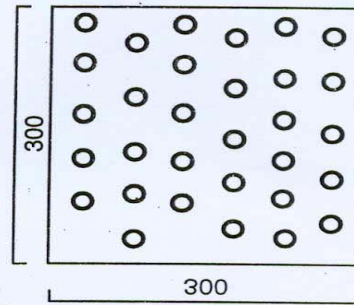
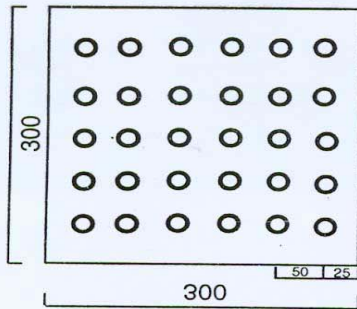

Fig-2. Details of Guiding/Warning Floor Material for persons with impaired vision.

Other Facilities

Counters

To make a counter easily accessible for a wheel chair user, allow a space about 700 mm high and 350 mm deep under the counter (as shown in Figure-1).

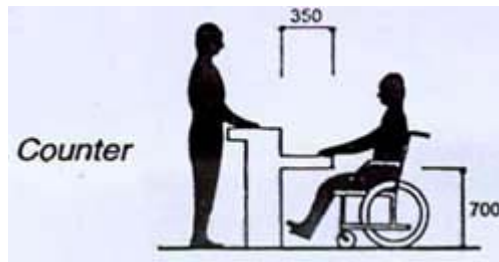

Fig-1. Counter

Water Fountains (Drinking)

Allow sufficient space around the water fountain to make it easily accessible for wheelchair users. Depending on the type of water fountain allow a space about 700 mm high and 350 mm deep under the fountain (as shown in Figure-2).



Fig-2. Drinking Water Fountain

Telephones

Allow a space about 700 mm high and 350 mm deep under the telephone stand. The telephone receiver must be placed at a height of 110 cm or less (as shown in Figure-3).

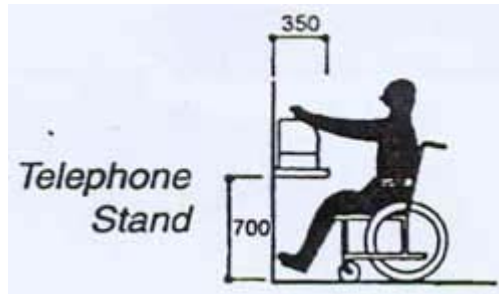

Fig-3. Telephone Stand & Wall Mounted Telephone

Mailboxes

The mail slot must be located at a height of 1200 mm or less (as shown in Figure-4).

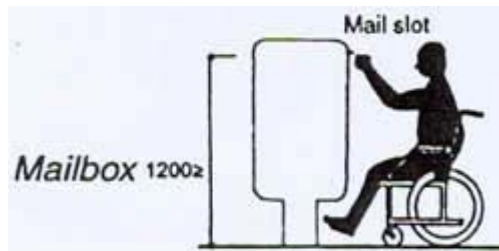

Fig-4. Mailbox

Vending Machines

The coin slot must be located at a height of 1200 mm or less (as shown in Figure-5).

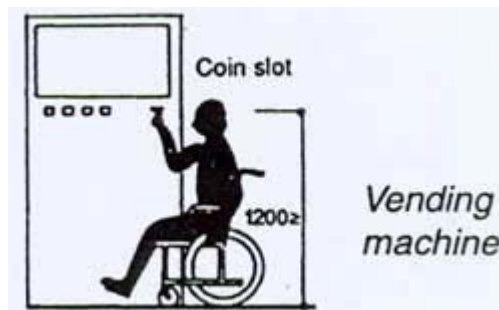

Fig-5. Vending Machine

Road Crossing

Figure-6 showing facilities for easy road crossing for disabled people.

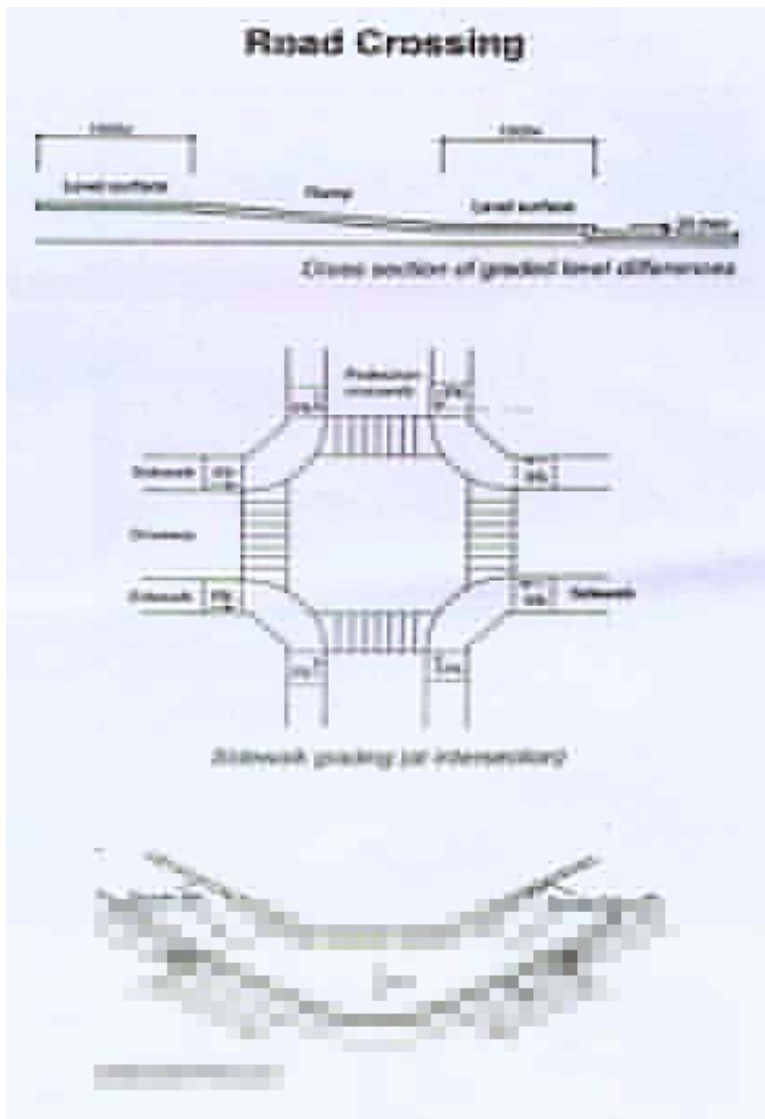

Fig-6. Road Crossing Facilities

Taxi Stand

Taxi Stand

- Two rows of guiding blocks for person with impaired vision should be provided 300 mm. Away from the taxi stand pole on the sidewalk.
- The taxi stand pole should be visible after dark.

For wheelchair users to be able to approach a taxi easily, sudden level differences from taxi stand to the Road need to be eliminated (as shown in figure-1).

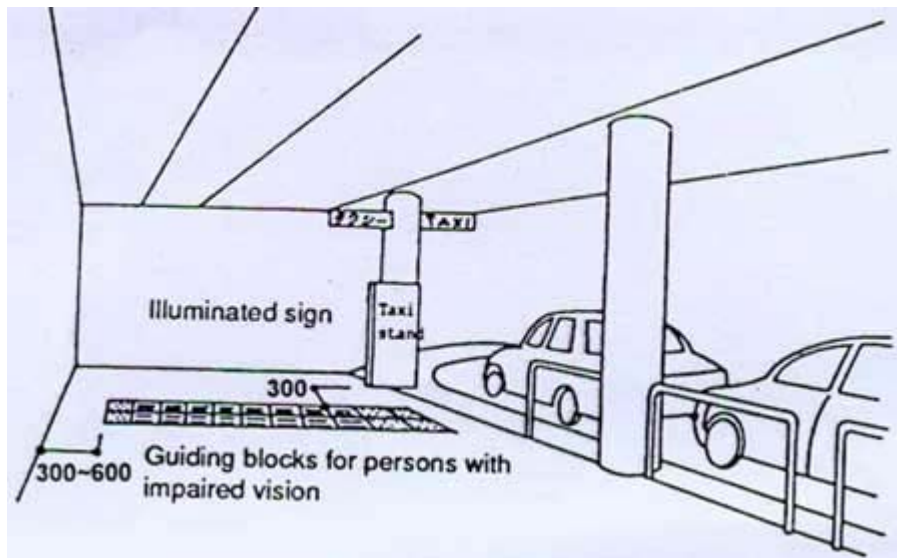

Fig-1. Taxi Stand

Taxi Interior

It is recommended that taxis be adapted to allow passengers to get in and out of them while remaining seated in their wheelchairs.

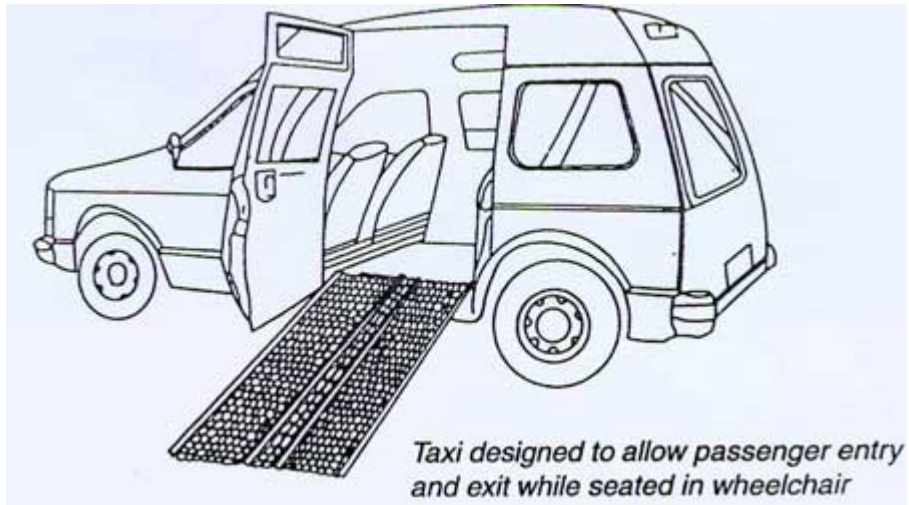

Fig-2. Taxi Interiors